

# AXM

**INSTALLATION  
OPERATION  
COMMISSIONING  
MAINTENANCE**

## **SUMMARY**

<b>1 -</b>	<b>INTRODUCTION</b>	<b>1</b>
	1.1 General	1
	1.2 Safety instructions	1
	1.3 Identification of the apparatus	2
	1.4 Delivery	4
	1.5 Handling / Storage	4
<b>2 -</b>	<b>MOUNTING</b>	<b>6</b>
	2.1 Assembly of sections	6
	2.2 DOORS	8
	2.3 Coils connections	8
	2.4 Technical corridor	11
	2.5 Roof for external version	12
	2.6 Washable bottoms	12
<b>3 -</b>	<b>START-UP/MAINTENANCE OF THE VARIOUS FUNCTIION</b>	<b>13</b>
	3.1 Air dampers/Mixing	13
	3.2 Air filters	14
	3.3 Heating and cooling coils	15
	3.4 Antifreeze probe drawer	18
	3.5 Electric heaters	19
	3.6 Cooling coils	20
	3.7 Fans / Motors	23
	3.8 Assembly of a flat pack delivered AX'M unit	28

# 1 - INTRODUCTION

## 1.1 General

Scope : the treatment of air

The AX'M may only be used for TREATMENT OF AIR (heating – cooling – filtration – humidification – dehumidification) and under normal operating conditions (altitude – temperature – relative humidity – pollution)

Unless specified to the contrary by  it is essential to remain within the characteristics of the range

External AHU : -20°C / +40°C Internal AHU : -20°C / +60°C maxi.

Cold fluid : +2°C / +7°C ou +2°C évap.

Hot fluid : The characteristics are given on the manufacturer's rating plate (Temperature and Pressure).



RESPECT THE NATURE OF THE FLUID MENTIONED ON THE PLATE

### CE MARKING : QUALIFICATION OF THE INSTALLATION

The AX'M should be installed and commissioned in accordance with all instructions given in this manual and the local regulations in force

Within the European Union, the contractor/fitter will have to draw up the :  
DECLARATION OF CONFORMITY and to mark the installation

## 1.2 Safety instructions

The AX'M installation and start-up work should be carried out by QUALIFIED PERSONNEL

Before starting work, the following safety instructions should be followed :

1. Cut off the electrical power supply before starting work.
2. All the moving parts should be stopped before starting work (motors, fans, pulleys, belts, dampers actuators, rotary, etc ...).
3. Wait for hot parts to cool down before starting work (hot water coils, electrical coils, motors, bearings, etc ...).
4. Wait for the internal and external pressures of the units to balance before starting work.
5. During installation or start-up, never exceed the specified pressures in the unit and ensure, in particular, that any dampers are open (if necessary take any timers or servo-systems into account).

### 1.3 Identification of the apparatus

#### Package and unit identifications

Depending on size and composition, the air handling unit is made up of 1 or more sections.  
The same package may include 1 or more sections

- Marking of each section : PACKING LABEL:

Affixed to each section of package :

- Name of the customer
- Model and size
- Order N°. And mark
- Customer mark
- Section No : M1, M2, etc...

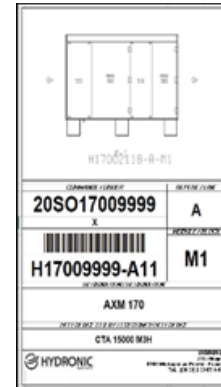

- Marking of the AIR HANDLING UNIT : COMPANY RATING PLATE:

Secured to the unit beside the fan section

Includes the characteristics of the unit with the order N° and mark

 HYDRONIC - ZI La Grippe - 61400 Mortagne-au-Perche - France Tel. : (00 33) 2 33 85 14 00	
	
<b>Serial No</b>	20SO17009999-10-1
<b>Type</b>	AXM 170   CTA 15000 M3H
<b>Motor</b>	1x7.5kW   TRI 400V   50Hz
<b>Electrical</b>	
<b>Fluid</b>	0MPa MAXI
<b>Date of Manufacture</b>	2017   Made in France

For a double-flow unit, there are 2 company rating plates, one for each fan section. The number of sections and their number appear on the unit drawing unit enclosed with the bag documents : M, M2, M3, etc... and their relative position for assembly

Each unit is marked with an accurate information marking (thanks to mark or pictograms).

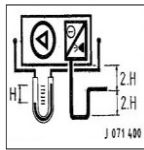

Condensate connection



The headers presence and the direction of the water flow

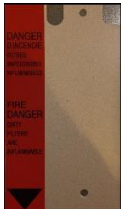

The presence of filters (flammability)

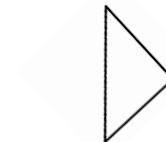

The direction of air flow

### DOCUMENT BAG

A certain number of documents are always enclosed with the unit :

- The instruction manual.
- The declaration of incorporation or certificate of conformity UE.
- Thue unit drawing

### BOX OF ACCESSORIES

A case or box of accessories is delivered in the fan section.

It contains the accessories required for the assembly and commissioning of the unit.

- Seals – threaded nuts and assembly bolts – covers (see connection block diagrams)
- Liquid for manometers and coupling caps
- Allen (hex. Head) key for opening the doors

## 1.4 Delivery

### Delivery / Reserves

AX'M units are delivered packed and FILM WRAPPED

At delivery of the equipment on site, it is ESSENTIAL to check that the delivery complies with the indications on the  delivery note

Prior to unloading please check your package. Any guarantee tape broken or visible damage to the housings or package must be subject to RESERVES raised immediately on the  delivery note before signing. The buyer must inform us with 48 hours of receipt, please comply with the legal provisions. Pictures are always useful in any insurance claim

**Send a registered letter to the  within 48 hours, setting out clearly the damage caused. A copy of this letter shall be sent to the manufacturer or his commercial representative**

**The warranty may not cover any damages if this procedure is not followed.**

### Precautions for storage

If the AX'M units are not installed immediately, it is recommended to keep them protected and to store in a clean dry place.

## 1.5 Handling / Storage

### Handling precautions

The handling equipment should be appropriate to the type of equipment, the size and weight of the housings and their final location.

**The AX'M installation and start-up should be carried by QUALIFIED PERSONNEL**



The device must be handled with care and only in a horizontal position. In the case where the device is handled by a spreader + slings, it is then necessary to place tubes through the holes reserved for this purpose in the transverse support legs.



Make sure that the rudder size is sufficient so that the straps do not exert any pressure on the unit and that the steel tubes are locked in translation. Observe the indicated slinging angles. A yellow label mentions the precautions to be taken.



A RED and WHITE tape and label indicate the presence of a condensate pipe under the AX'M and which must be avoided with the FORKS.

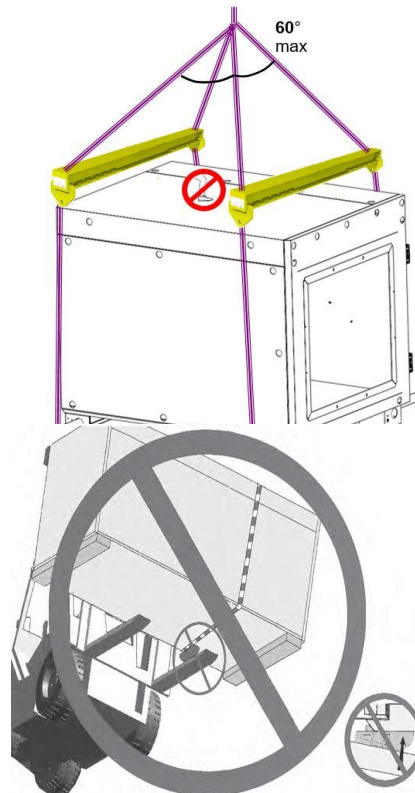

Location

Appropriate access should be provided for future maintenance or after sales operations.

The AX'M casings are fitted with transversal feet made of thick metal sheet. They may therefore be installed directly on a flat floor.

The flatness of the floor and the horizontal position of the unit should be sufficient to allow a good interconnection between sections and a good tightness

**Failure to comply with these criteria makes our warranty null and void**

A clear space should always be provided around the unit especially on the access side for the replacement of filters (an operation which is repeated regularly) or the replacement of the coils or fans (exceptional one-off operation).

The clear space should be at least one width of the unit on the access side and at least 50 cm opposite the access (passage for a man).

The design of the AXM unit with hinged doors **ALLOWS FOR THE PRESENCE OF LOCAL OBSTACLES** (posts for example) on the access side of the unit, without affecting the various servitudes.



However, it is essential to ensure that such obstacles are not opposite removable components such as filters, batteries, and especially **REMOVABLE DRAIN TRAYS**.

AXM units may be located **OUTDOORS**, provided that the unit was ordered with this in mind. Make sure that this is the case (in particular the presence of a roof).

Always provide sufficient height for the siphon. If necessary, install the sections on spacers  
See siphon paragraph

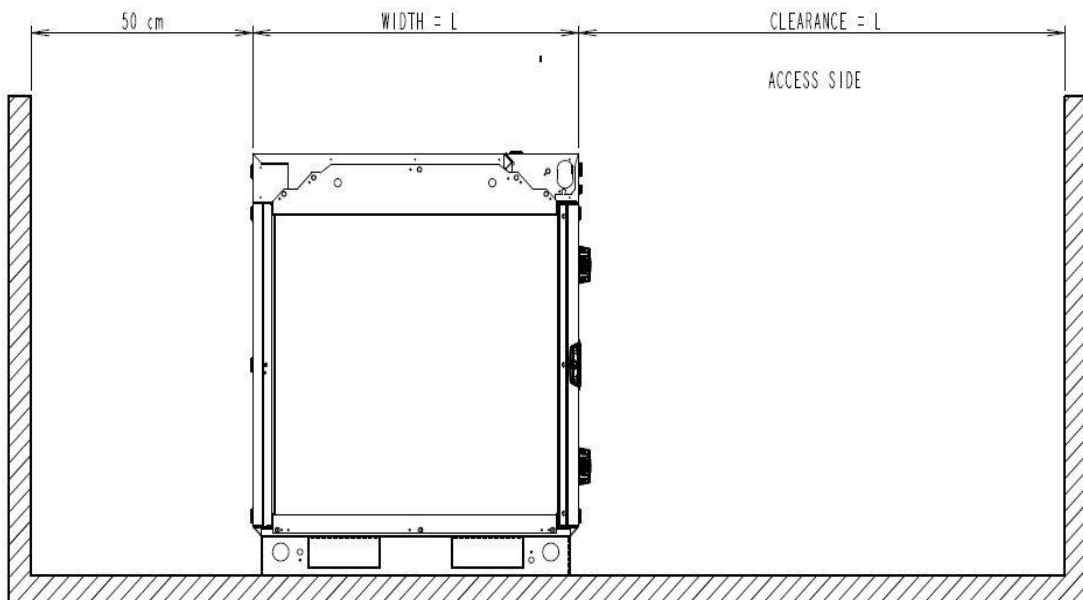

## 2 - Mounting

### 2.1 Assembly of sections

The service sides must all be on the same side. They are fitted with the following

- TECHNICAL CORRIDOR
- HINGED DOOR
- COIL HEADERS
- MARKINGS

The direction of the air flow is shown by an triangular arrow.

**All accessories required for the assembly of the sections are in the box of accessories.**

Before bringing the sections together and starting to assemble them make sure the various seals are fitted, they ensure the continuity and sealing of the AX'M unit



All seals must be aligned with the internal edge of the unit

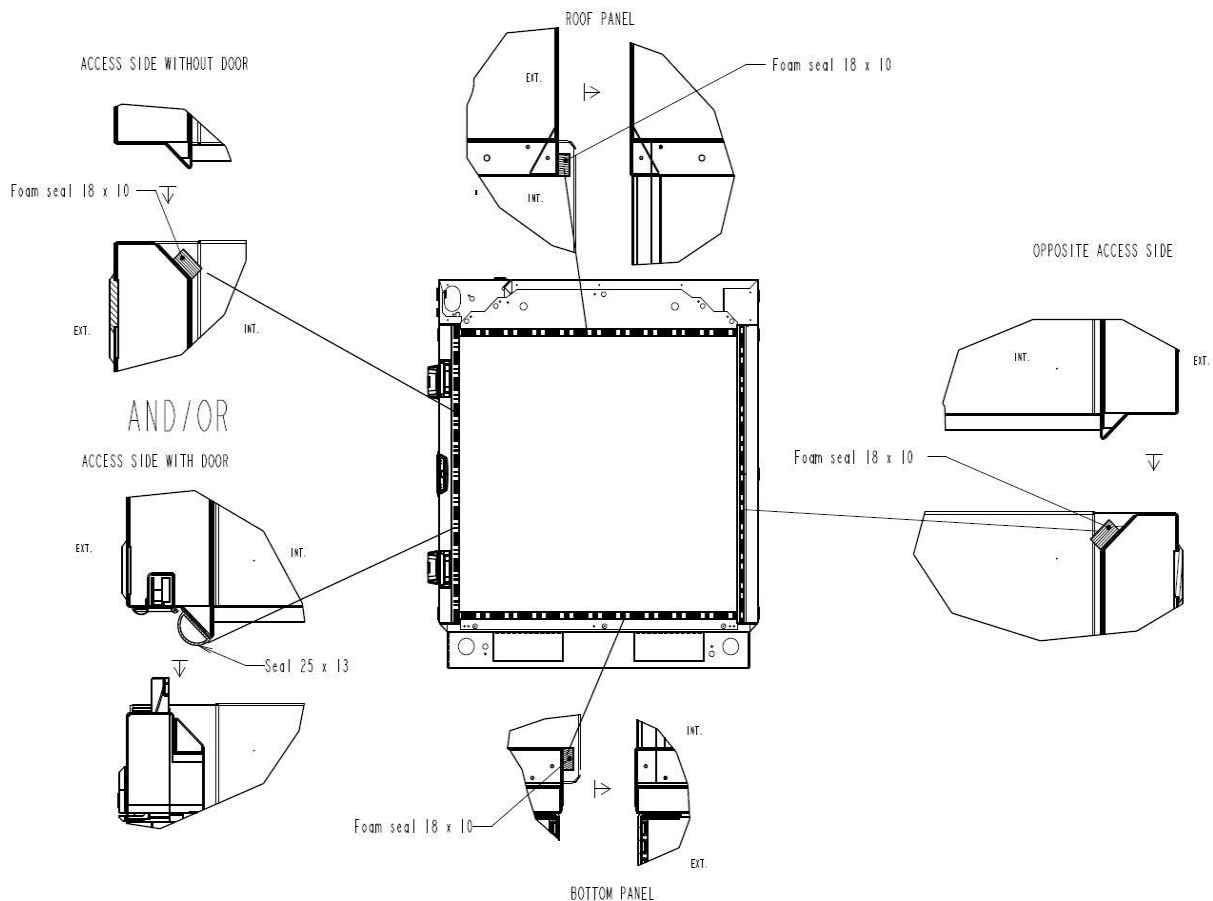



The sections should be assembled outside the bodywork, using 4 tensioners, but they may also be assembled internally on an ad hoc basis  
The tensioners should be fitted and screwed on to 4 corners of the AX'M

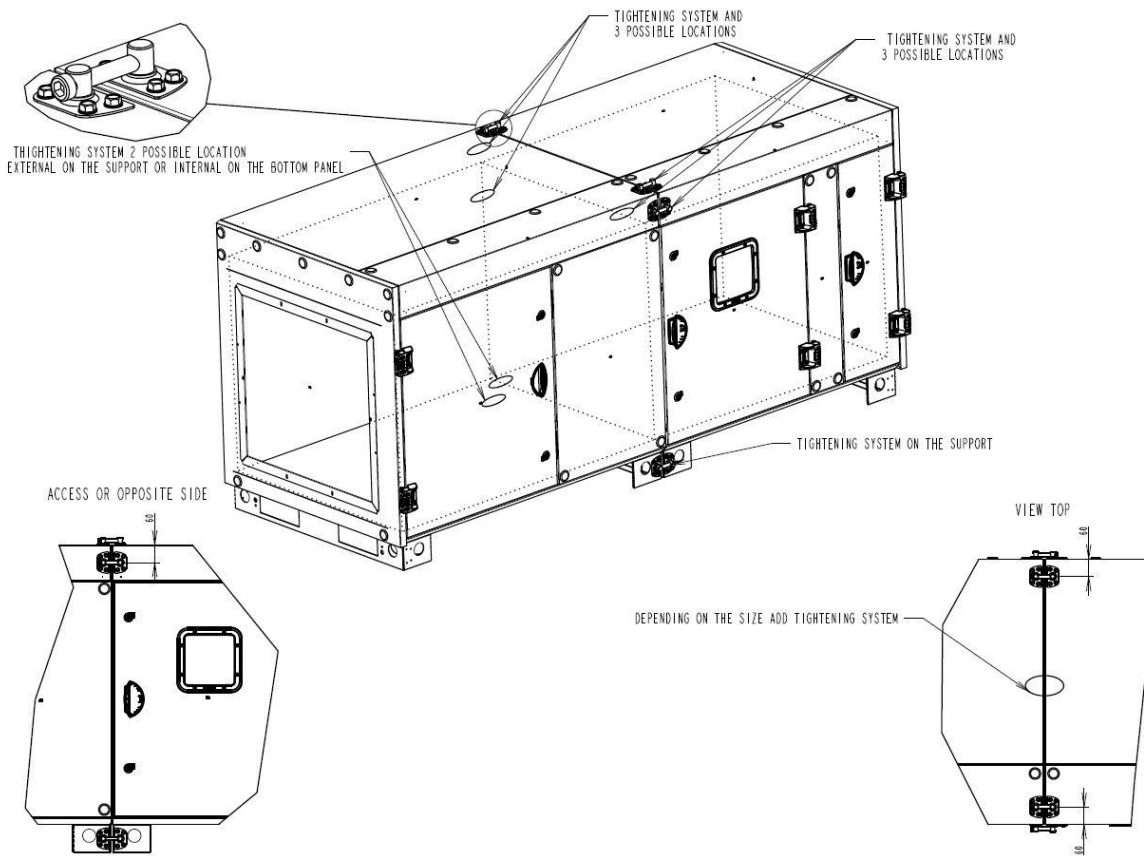

**2.2 DOORS**

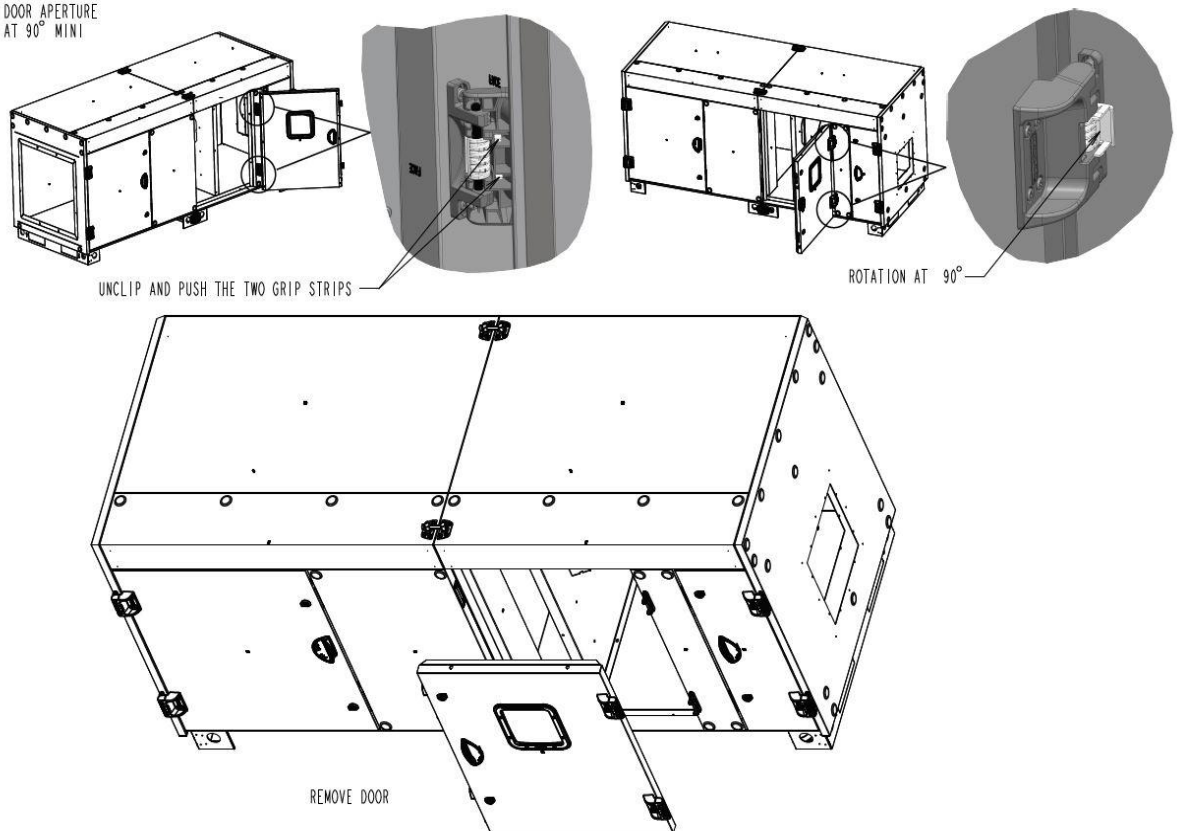

**2.3 Coils connections**

The headers outlets of the heating or cooling coils are located side by side in the technical panel.

The pipework connections may be made in different directions :

- Downwards
- Upwards
- Across the top of the AX'M.



For the cooling coils (chilled water or direct expansion) **MAKE SURE THAT THE PIPEWORK DOES NOT HAMPER THE REMOVAL OF COMPONENTS** such as the **REMOVABLE DRAIN TRAY, ANTI- FREEZE PROBE RACK or DROPLET ELIMINATOR**

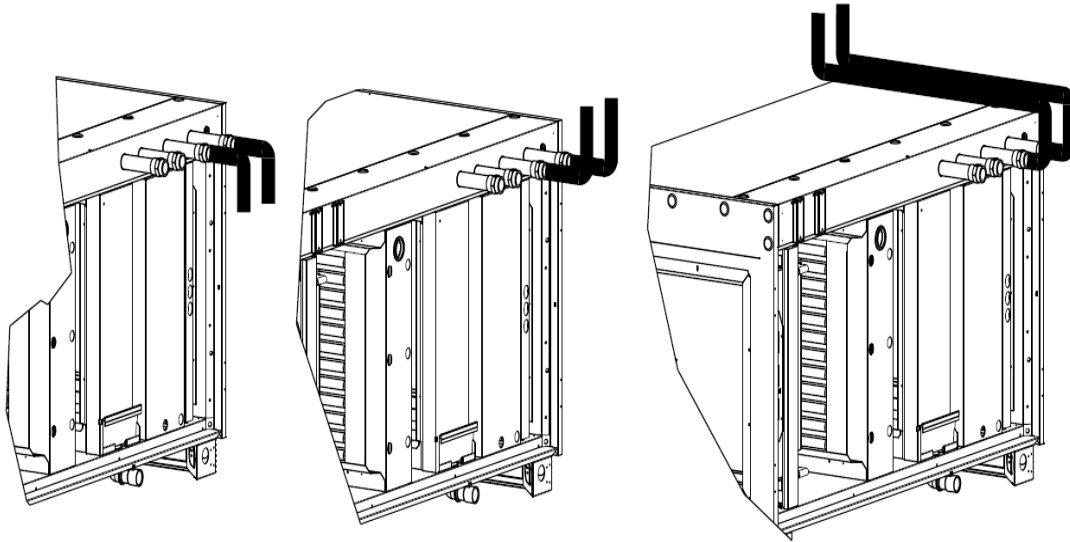

Take into account the thickness of the insulation and other accessories in the design and geometry of the pipework.

**DRAINS :** - Each header is supplied with a threaded union including a location for a DRAIN, plugged. 2 NPS 6 5x10 1/8" Use a 13 mm spanner.

**DRAINING THE COIL :** - A drain plug is installed in the bottom of each coil. Use a 17 mm spanner. To reach it, the header cover must be removed. Use a 10 mm open end wrench for the heating coil. Use a 10 mm box spanner for the cooling coil.

**REMOVABLE DRAIN TRAY :** - Each cooling coil is fitted with of a sloping **STAINLESS STEEL** tray, that is easy to **REMOVE** for cleaning or inspection.

Release the **TRAY** by pulling it to approximately 45° to clear the condensate outlet (which is fixed), and remove it laterally. Removing the tray does not require disassembly of the condensate drain pipewor

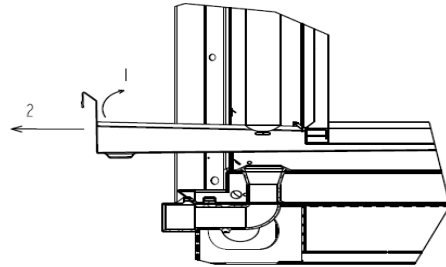
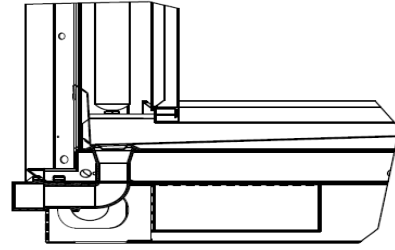
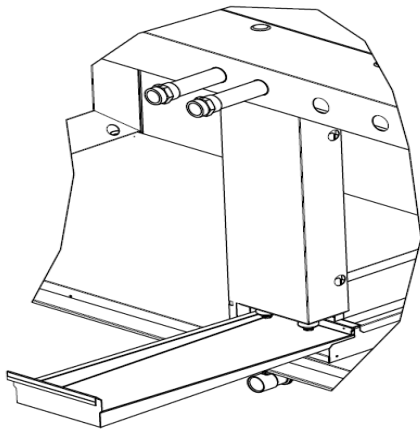

REMOVE THE TRAY BEFORE TO REMOVE THE COOLING COILS

**2.4 Technical corridor**

The total access made possible by the sliding doors means that nothing must be mounted on the doors.

The technical corridor in the top part of the AX'M unit runs along the entire length of the façade and is designed to be fitted with all fixed components, such as :

- Coil headers (see above),
- Tube filter pressure gauges (supplied as standard),
- Dial pressure gauges,
- Pressure switches,
- Lighting switches,
- Proximity switches,
- All control and measuring devices.

It allows panel crossings for all connections

The technical corridor is fitted with a top access panel (easily removed using 4 attachment screws). This access facilitates the installation and wiring of control components. In addition, it allows for the wiring of the entire unit, with the multi service bulkhead used as a cable tray along the entire length of the unit.

At each end of the housing, plugged openings are provided for cables

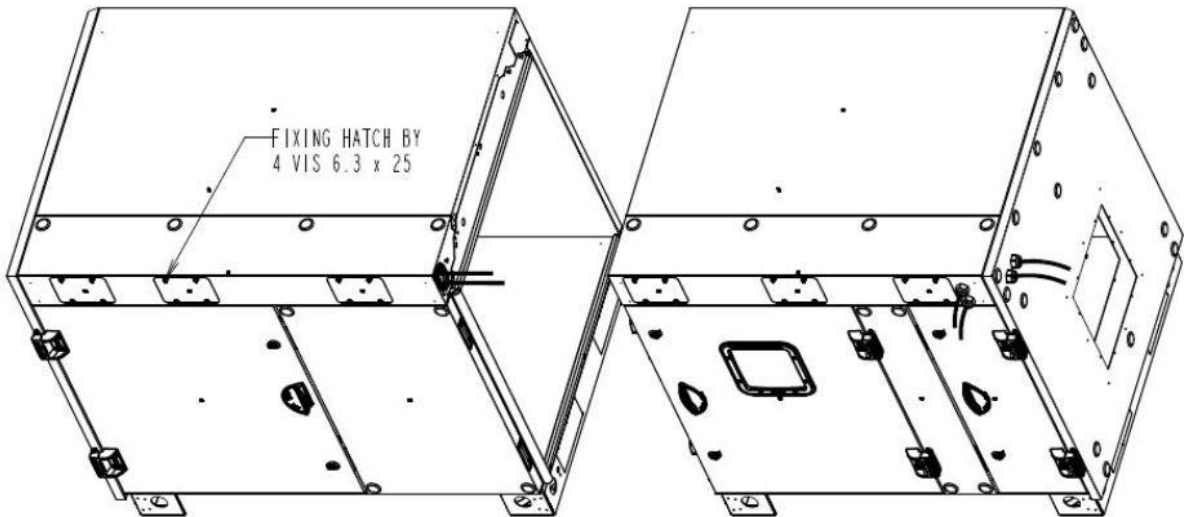

## **2.5 Roof for external version**

The outdoor version of the AIR ACCESS units is fitted with a roof.

This roof is supplied in the HORIZONTAL position for transportation reasons.

When the unit is commissioned, it is necessary to raise it in its final position (connection side) and fix it using the steel profile provided for that aim.

- 1. The steel profile the and sloping roof are designed so that the multi service bulkhead is always accessible.*
- 2. For side by side units, the central section of the units receives the water.  
The two edges of the side by side sections will make a drainpipe thanks to a seal located between those edges*

## **2.6 Washable bottoms**

In the case of sloping sections, ensure that the section bottoms are properly sealed to avoid any by-pass of air. These are intended only to evacuate washing water, they do not require siphon

### 3 - START-UP/MAINTENANCE OF THE VARIOUS FUNCTION

#### 3.1 Air dampers/Mixing

##### Ful size damper

Our dampers are all fitted with a shaft allowing either MANUAL operation using a locking device or MOTORISED operation by actuators.

The actuators may be supplied and installed in the factory or supplied and installed by you. In this case, check the installation possibilities (overall size) and technical data (torque) in relation to the dampers.

Before start-up, perform the following checks :

##### **For the manual version :**

- Rod is locked on to the shaft of the damper,
- No hard spots during rotation,
- Opposing blades overlap correctly,
- Flats correctly positioned (open on start-up).

**In the automatic version**, also check the following :

- Actuator power rating,
- Actuator electrical power supply or connection,
- Actuator travel and, if appropriate, limit switch,
- Correct direction of operation

##### Mixing box

The above remarks all apply. In addition, check the combination of the dampers and their marking (which is open and which is closed). The actuator can be fitted internally (standard) or externally (optional)

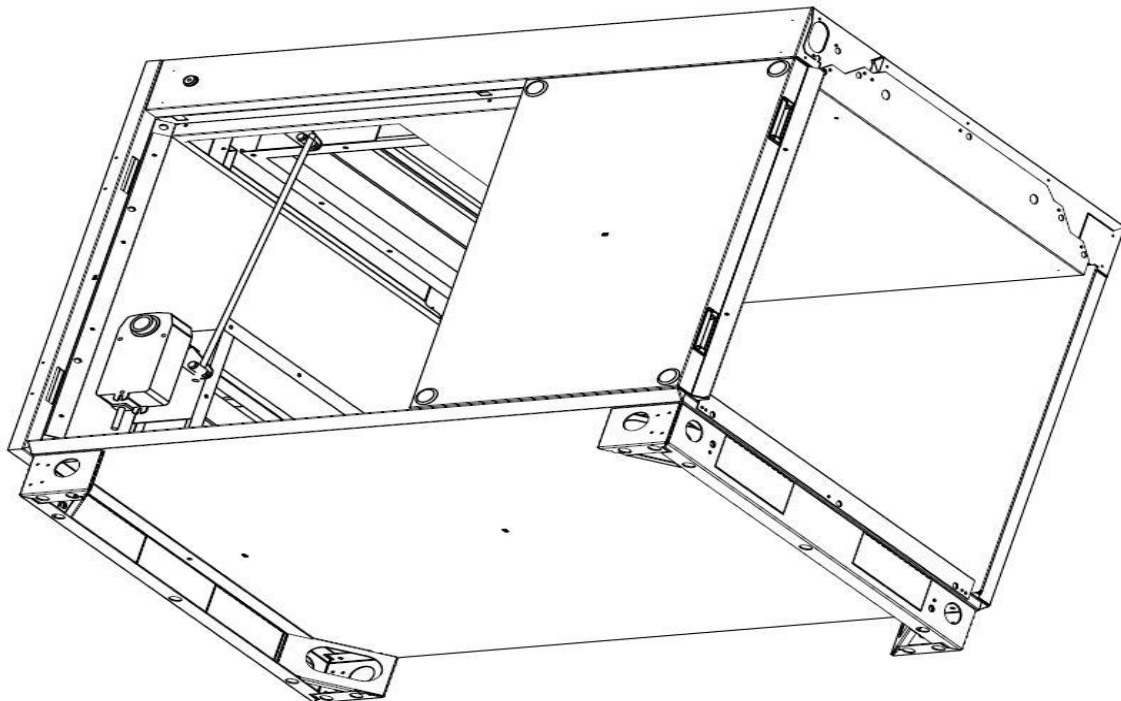

### 3.2 Air filters

In all cases, by default and unless specified to the contrary, all filter stages are fitted with a liquid level manometer giving an immediate reading of the pressure drop and therefore the notion of clogging.

This reading should trigger the replacement of the filter media, if necessary, depending on the type of application and the instructions in place.

For information only, for a given application the instructions might be :

- Replacement of G4, every month,
- Replacement of F5 to F8 every 2 to 3 months,
- Replacement of F9 or H10 every 5 to 6 months,
- Replacement of H11 to H14 every 2 to 5 years.

Each filter performs its own function

and also protects the next filter. On

start-up and after replacing a filter,

check the following :

- Filter cells present and in good condition,
- Air flow direction shown on the cells, if applicable,
- Seals correctly located, particularly the seal which supports the sliding doors of the AIR ACCESS,
- Cells correctly fastened, either in the tightening sliding rails (check the position of the device) or in frames (attachment systems),
- Dimensions and characteristics of the spare filter cells compared to the original,

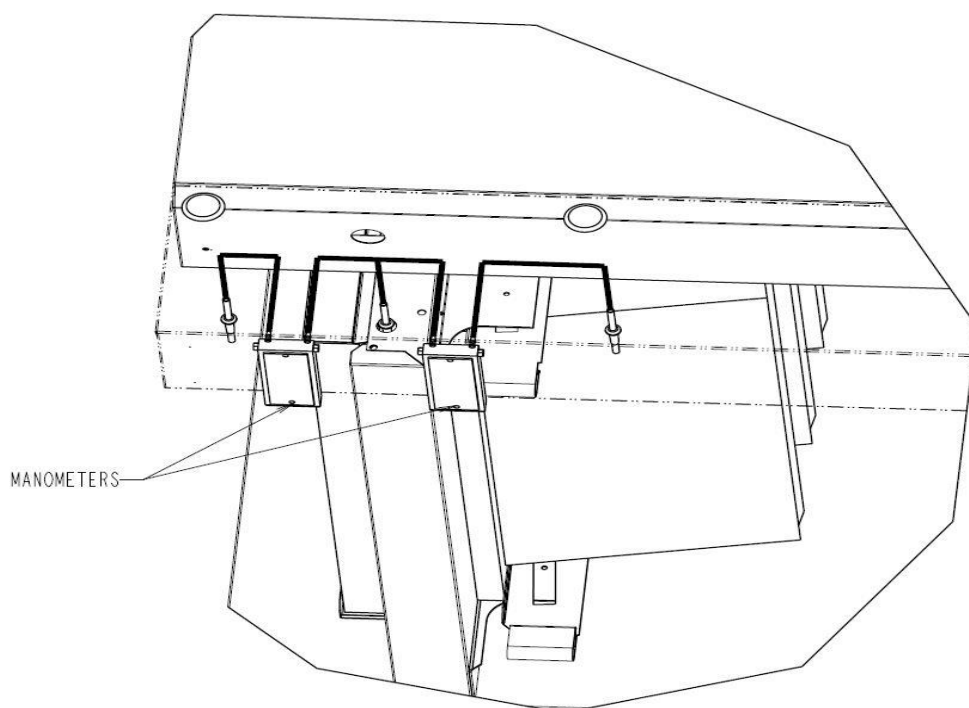

Manometers, add liquid (\*)

- => 2 pressure tapplings (\*),
- => 2 miniature threaded plugs (\*)

(\*) In accessories box



### 3.3 Heating and cooling coils

They are connected with HOT or SUPERHEATED WATER. STEAM must not be used (see pages 7 and 8 – Special features of the AIR ACCESS – coil headers).

Make sure that the nature of the fluid used and the limits of use comply with the indications on the rating plate of the unit.

During start up, always make sure that the coils are supplied with water in accordance with the selection and, more generally, opposite direction of the air flow.

Commissioning – replacement of a heating coil (valid for a replacement or installation in an empty section).

- INSTALLING A COIL IN AN EMPTY LOCATION
- REPLACEMENT OF AN EXISTING COIL

#### Water filling

Follow best practices and ensure that the pipework is supported independently from the unit.

REMOVE ALL ACCESSORIES AND CABLE THEN REMOVE PLUGS BUTTONS AND THE ACCESSE SIDE

#### Disassembly technical corridor

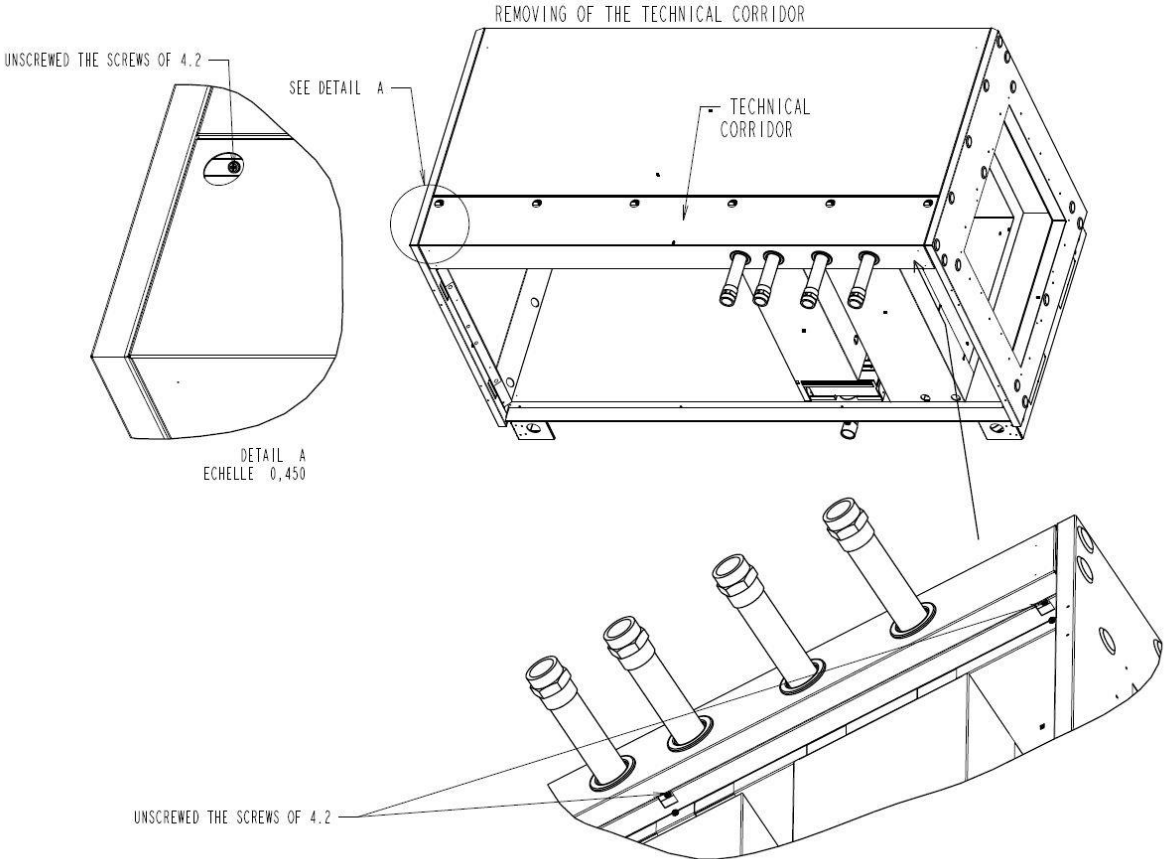

Remouving of the slide

REMOVING OF THE SLIDE

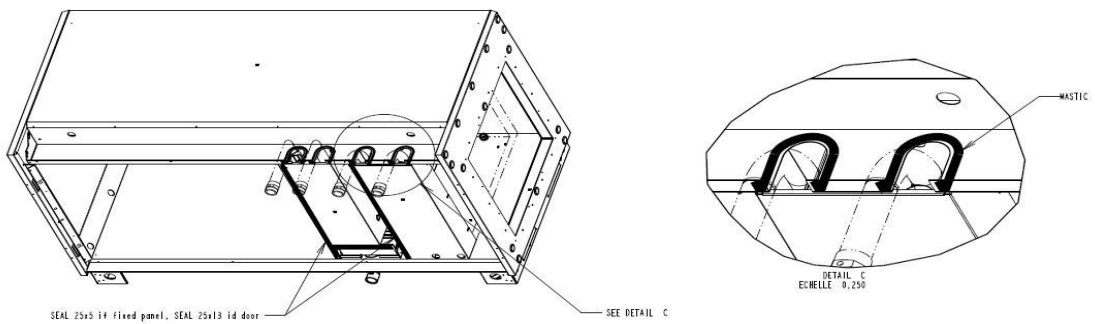
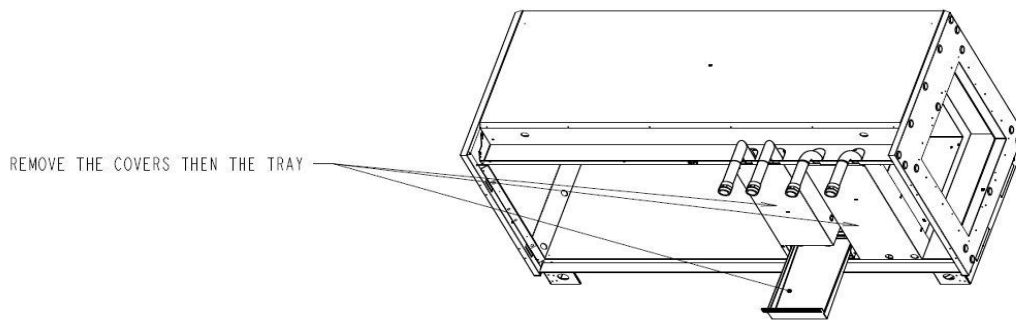
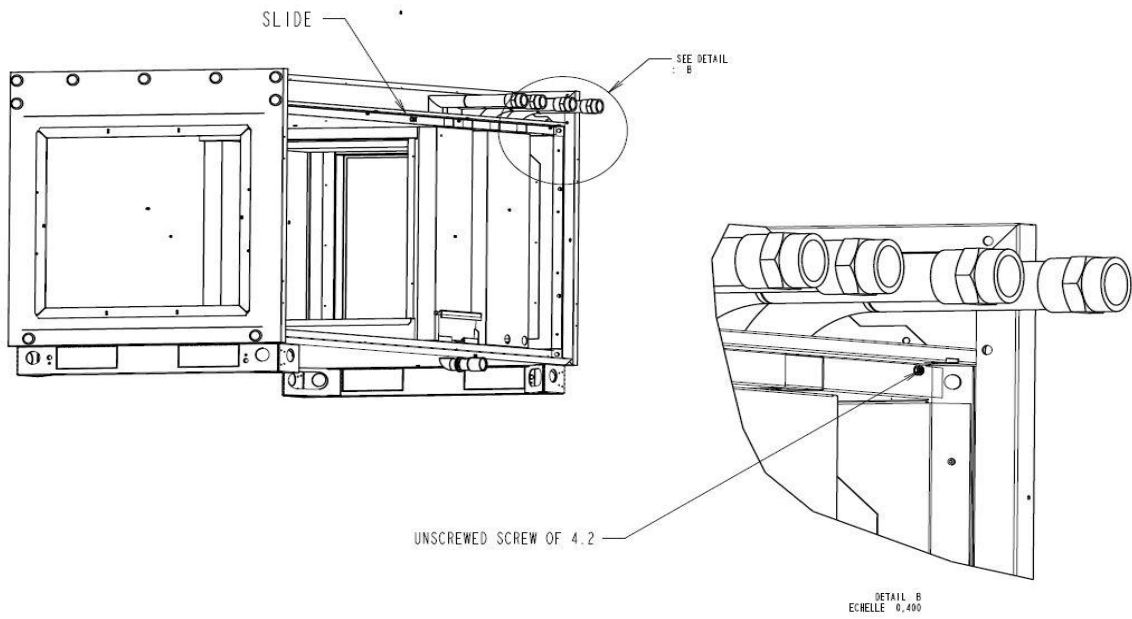

Clearance batteries

REMOVING BATTERIES

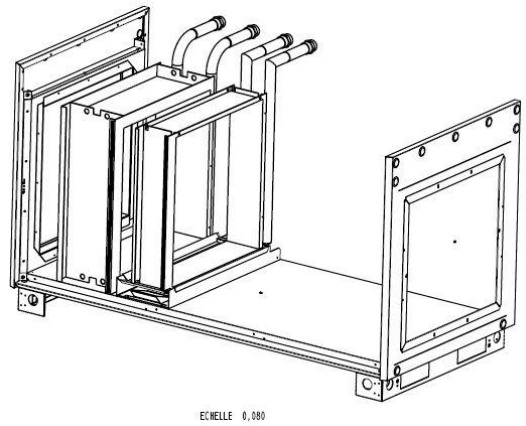
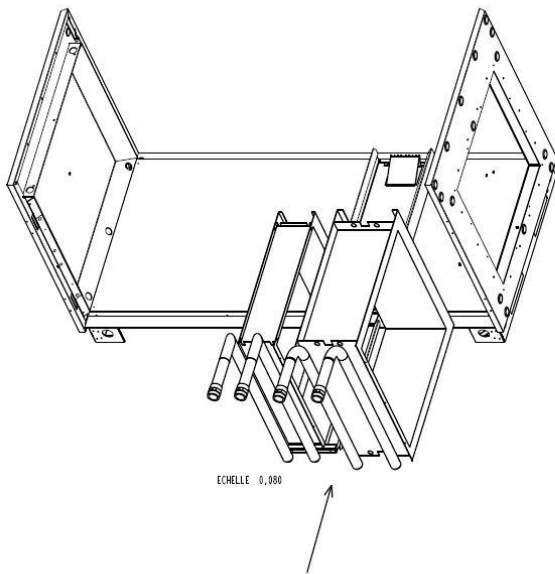

EN

### 3.4 Antifreeze probe drawer

The rack fitted with its anti-freeze capillary thermostat, stretched throughout the front section is installed on a slider.

It is wired through the multi service bulkhead. Provide sufficient electrical cable length to be able to remove the rack partially to inspect the probe.

Installing the thermostat inside the unit avoids the problem of unwanted tripping in outdoor units. If the thermostat is not supplied by CIAT, check its compatibility and overall dimensions.

Remove it partially from the rack, secure the thermostat on the frame, stretch it and secure the capillary over the entire cross section of the air duct. Connect by passing the cable up through the multi service bulkhead.

Coils not used in winter must be emptied, check drain plug. The internal circuit of CIAT coils is specially designed to allow complete draining. If the coils are used during the winter and operate in external air, it is necessary to take proper precautions to prevent frost : glycol, anti-frost dampers, anti-frost probe drawer which forces the hot only valve and stops ventilation.

The location of anti-frost protections must be determined according to the required protection and safety.

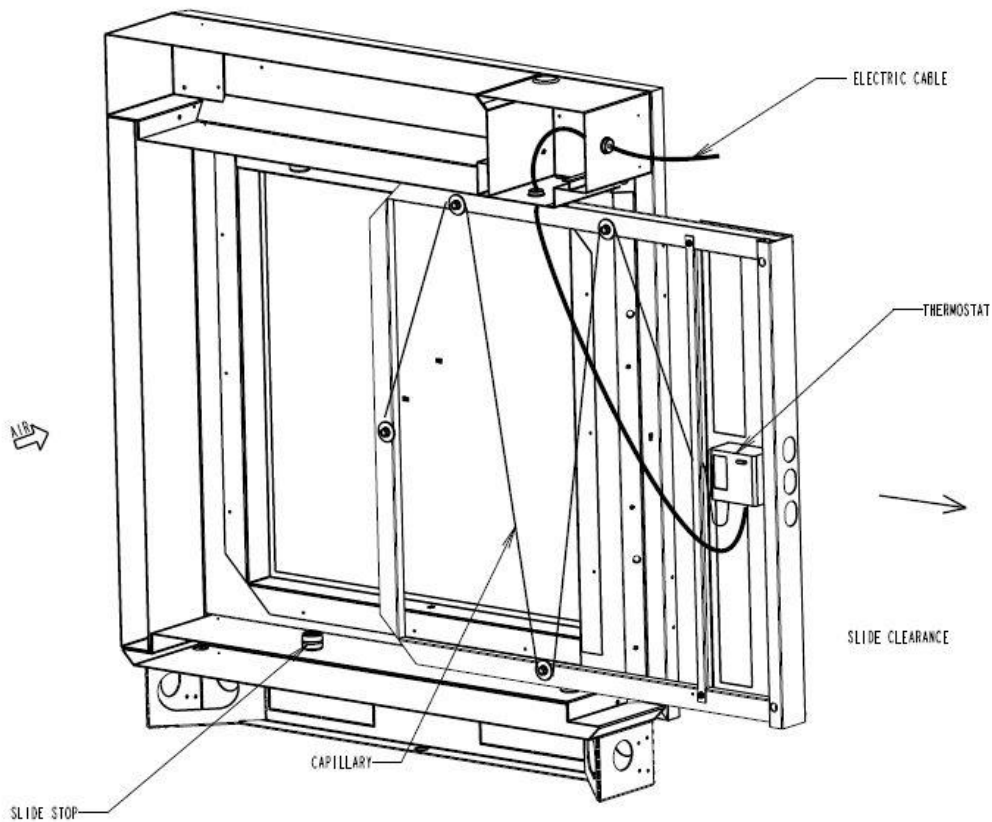

### 3.5 Electric heaters

#### **Installation**

To wire the electric heaters, locate the removable cover and remove it to gain access to the connection strips of the electrical elements.

Connect the heater in one or more stages steps, as determined on ordering. Use the grommets provided to route the cable to the the multi service bulkhead.

Connect the two thermal safety devices in series in the control circuit.

- One is reset automatically and cuts out at about 80°C,
- The other is reset manually and cuts out at about 115°C.

They must only be reset after checking the installation and finding the reason for the trip.

#### **Control**

In addition to the wiring of the two thermal safety devices, a certain number of precautions must be taken in the regulation circuit. SLAVING



All or part of the electric heater should only be allowed to operate if ventilation is running. Accordingly, the electric heater must be slaved to the fan motor.

In addition, to overcome a possible belt failure, install an air flow detection system

suas a differential pressure switch. TIMER

Before any scheduled shutdown of the ventilation, stop the electric heater a few minutes beforehand, to dissipate the heat accumulated in it into the air. Allow a time delay of 5 to 10 minutes.

#### PROPORTION

In case of a variable speed, where a two-speed motor or frequency inverter is installed, the control system must ensure that any variation in the air flow rate results in a proportional reduction in the electric heater power drawn.

#### MINIMUM SPEED

In all phases of operation, a minimum air speed of 2 m/s is required.

#### **Maintenance**

After start up, tighten the terminals after 48 hours.

Thereafter, on a regular basis, check the condition of the electrical components and condition of the terminals for signs of significant overheating, and check the connection of the safety devices.

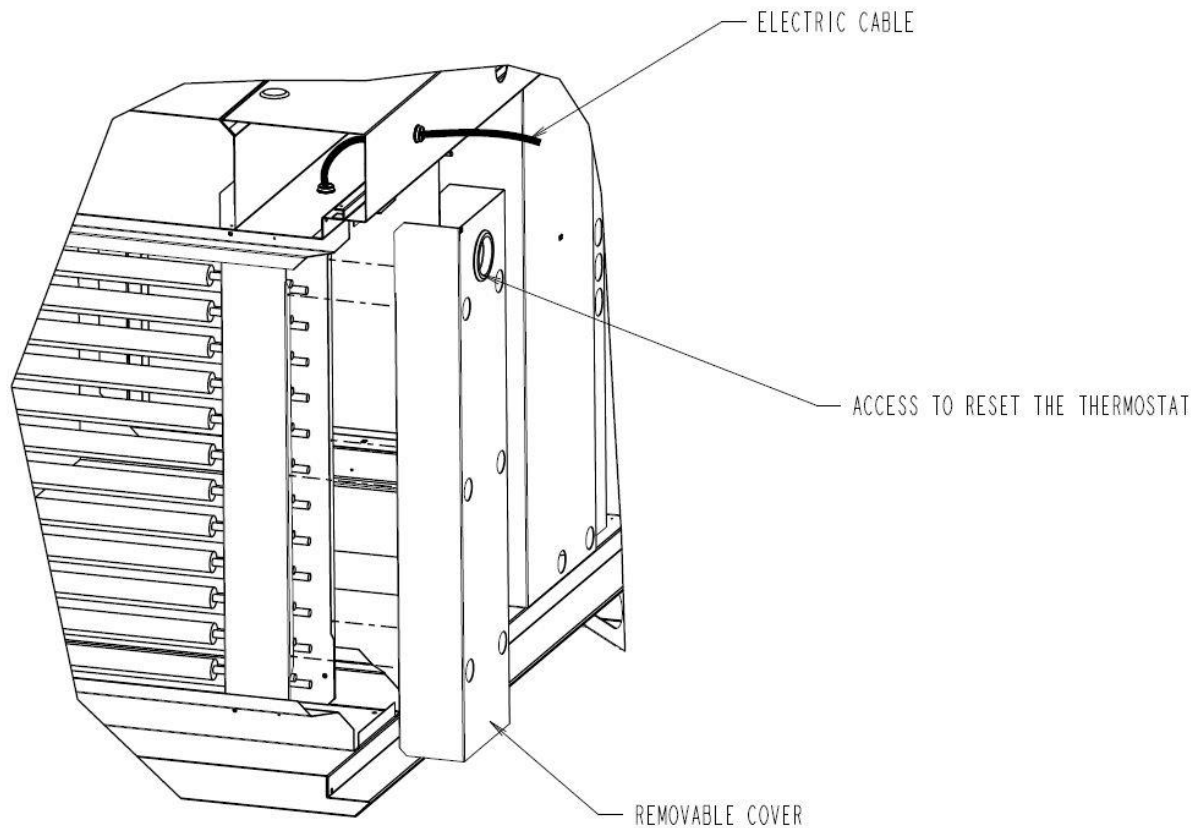

### 3.6 **Cooling coils**

Cooling coils must be supplied with CHILLED WATER. Refrigerant fluids must not be used. For direct expansion coils, see below.

On start up, always make sure that the coils are supplied with water flow in the opposite direction to the air flow.

Provide flanges and isolating valves on the pipework to be able to replace the coil by clearing its sliders through the multi service bulkhead (see sketch)

Cooling coils are installed on sliders above the condensate drain tray which is also REMOVABLE .

#### REPLACEMENT OF AN EXISTING COIL (see paragraph 3.3)

The AIR ACCESS unit is fitted with a condensate drain under the removable drain tray which must be

The siphon, sized as shown below, is intended to counter the negative pressure beside the cooling coil, to allow the condensing water to flow.

The stainless steel drain tray slopes to avoid stagnation inside the unit. The condensate flows towards the drainage bend where, thanks to the siphon, they drain into the sewer.

**Note :** Respect the outlet diameter of the drainage bend

Never use reducers

Lay the drain line sloping (approximately 5 in 1000 slope) to encourage free flow from the Siphon to the drainage network

We recommend inserting a control gate in this line

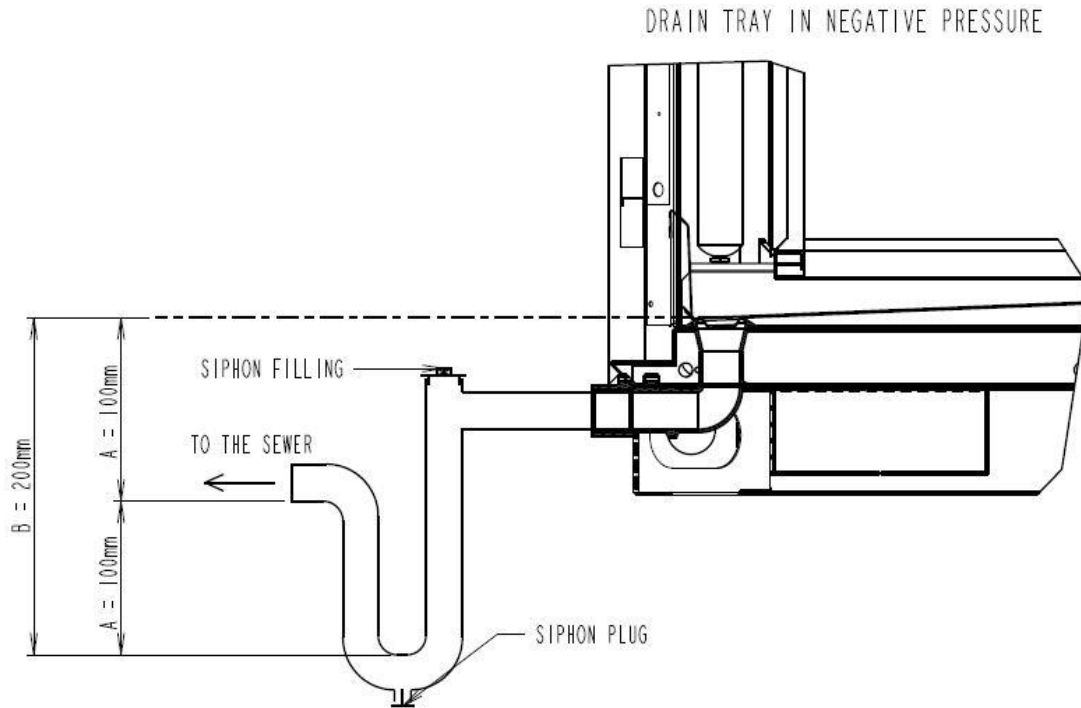

Dimension "A" should always be twice the negative pressure in the section in mm.  
The sketch above gives the dimensions to be respected for a negative pressure of 50 mm Water Column or 500 Pa

## DX coils

The entire piping at the bottom of the DX coil is not provided. It is part of the installer supplies for the connection

Collector mounting diagram

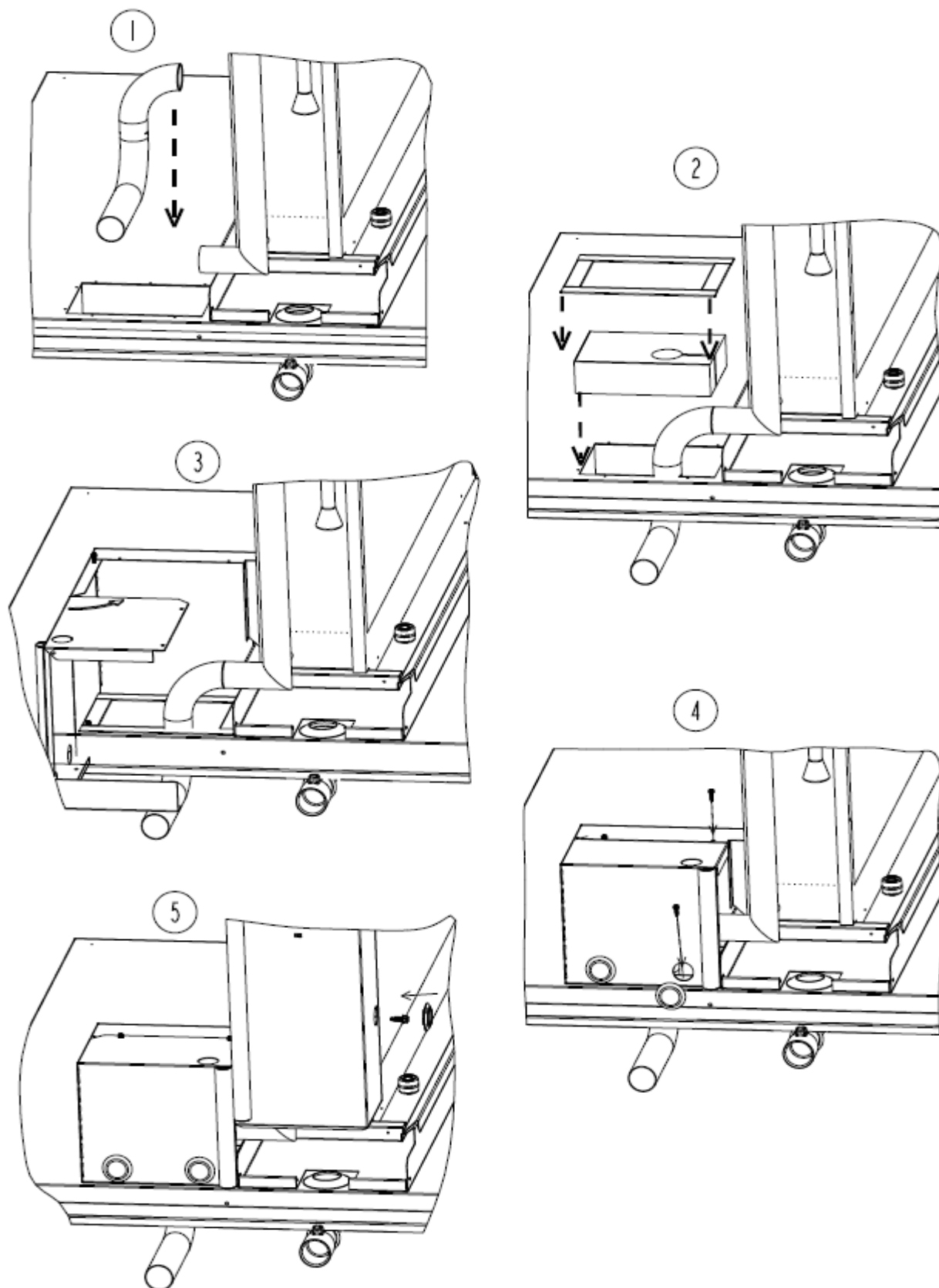



### 3.7 Fans / Motors

#### Air handling connections

Double inlet fan sections or plug fan sections are always insulated internally by **flexible seals** or **flexible sleeves** and **rubber pads** or springs.

If the double inlet box is at the end of the unit, the connection of the duct to the unit may be flexible or rigid, using the surface gauges provided on the discharge panel.

For good operation of the fan, a straight length of duct of at least 1.5 times the diameter of the blow and with no restrictions should be provided.

*Example with RDH 500 fan, provide  $L > 750$  mm*

**Note** : the network of ducts should be self-supporting and, under no circumstances, supported by the unit.

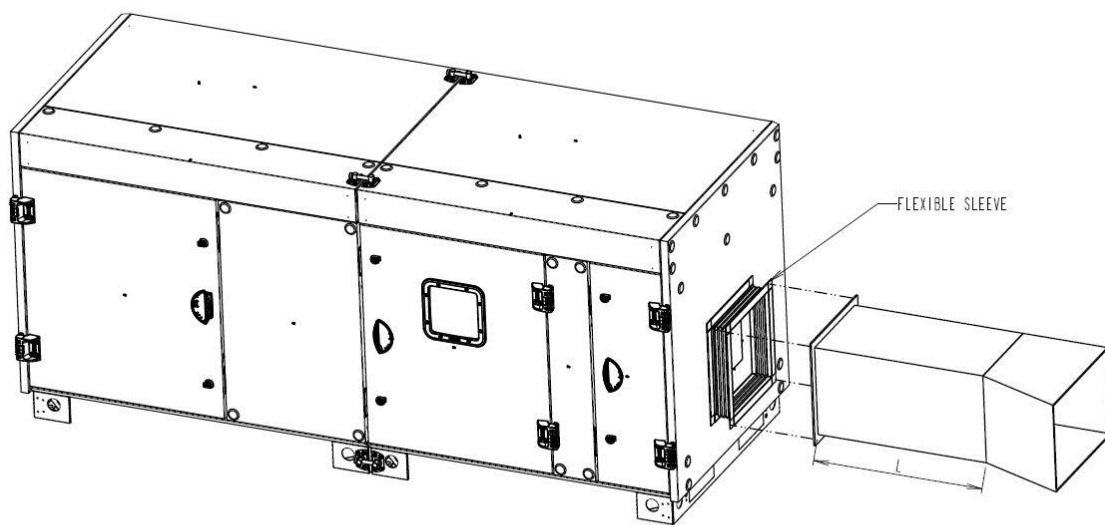

### Electrical connection

#### **Please comply with local regulations and standards in force (e.g. NFC 15100 in France)**

The electric motors used in Air Access units comply with European standards, with high efficiency (EFF 2), three-phase, 50 Hz, and fitted with thermal protection.

Check that the type of thermal protection (PTO or PTF (normally open/closed thermostat), PTC (Positive Temperature Coefficient) etc.) is appropriate to the control system of the installation.

Information concerning the start-up of these motors is given by the manufacturer. For electrical connections, choose the right cable size and following the connection wiring diagram supplied with each motor.



Connect the thermal protection.

#### **MAKE THE BEST USE OF THE MULTI SERVICE BULKHEAD AND OF THE CABLE PASSAGES IT PROVIDES BY ITS UPPER ACCESS.**

If necessary, make the connection using a proximity switch installed in the multi service bulkhead of the Air Access.

Note : After 48 hours in operation, it is essential to perform an inspection and tighten the connections.

Grommets motorconnectiontothenetwork (Grommetsareinstalledinthefactory)

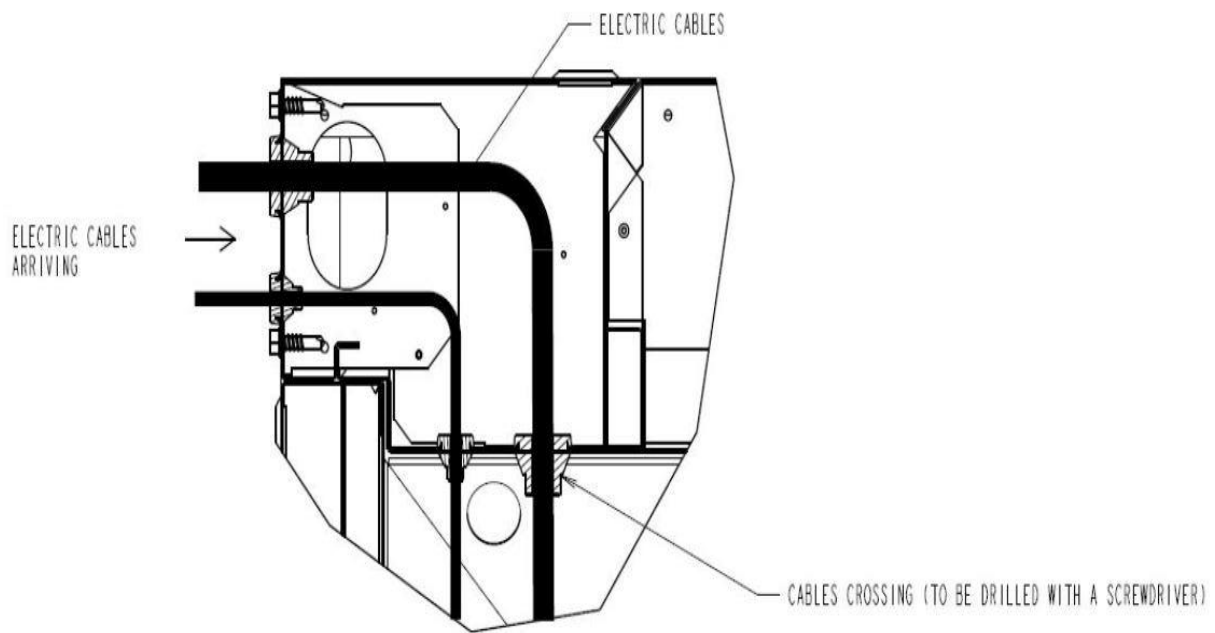

**One speed motor**

4 pôles : 1500 rpm

2 pôles : 3000 rpm

6 pôles : 1000 rpm

8 pôles : 750 rpm

Up to 4kW 230V with D

connections ▲, 400V with Y connections

From de 5.5Kw 400V with D connections ▲, 690V with Y CONNECTIONS

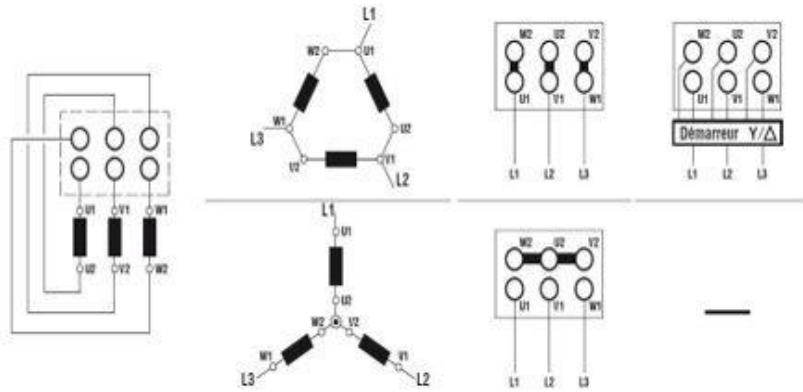

**Two-speed motors with DAHLANDER winding :**

4/8 pôles 1500/750 rpm

2/4 pôles 3000/1500 rpm

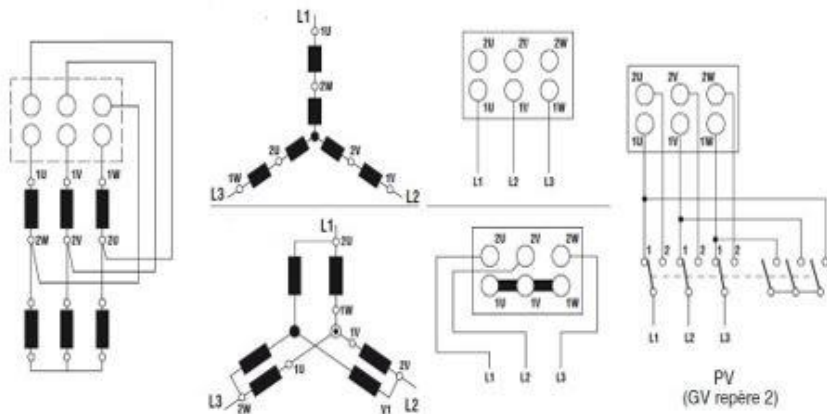

**Two-speed motors with 2 separate windings**

4/8 pôles 1500/750 rpm

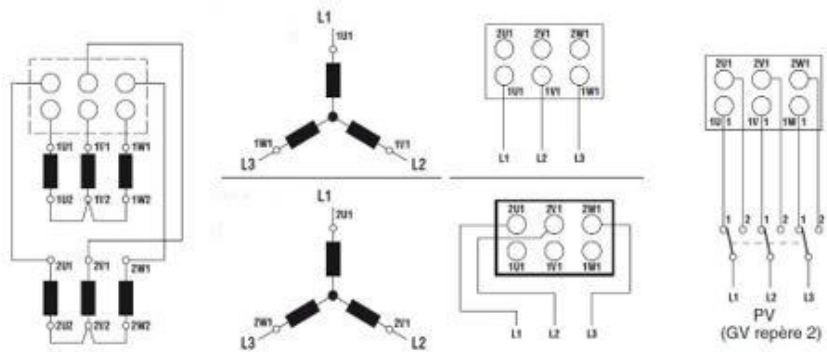

## Operation

A certain number of checks must be performed before starting up.

Electrically : check all connections, the insulation of the phases, the connection of the thermal safety device and, in particular, the direction of rotation of the motor and fan. If necessary, reverse 2 phases

Make sure that a voltage drop is not created when the motor is started and that all 3 phases are balanced. Measure the electric current strength requirement and compare it with the value on the motor rating plate.

Mechanically : check the efficiency of the anti-vibration insulation and the operation of the rotating machine :

- Tension of the belts,
- Alignment of the belts,
- Centre distance between the impeller and the scroll casing,
- Temperature of the bearing supports

## Plug fan

Without a transmission system and with the motor mounted on the end of the shaft, this type of ventilation requires the use of a frequency inverter, which may be offset or mounted.

Check the rating of the motor and frequency inverter, according to the selection frequency and rated speed of the motor (e.g. 1500 or 3000 rpm).

### **Air flow measurement loop**

Each plug fan is fitted with a pressure tapping in the draft-tube cone which is connected to the multi service bulkhead of the AIR ACCESS in the factory.

Another pressure tapping in the section upstream from the plug fan is also connected to the technical panel and is used to read the difference in differential static pressure and to calculate the air flow rate using the formula here below.

Check the type and make of the plug fan on the Company rating plate. The K coefficients for 2 different makes of fan are given below.

Ø DIAMETER	K			
	NPL	NPLalu	NPA	NPAalu
200		31		
250	49			64
280	60			80
315	74		101	
355	100		134	
400	139		173	
450	178		192	
500	218		259	
560	268		329	
630	349		413	
710	455		558	
800	566		683	
900	700		878	

K = calibration factor depending on wheel size

$p$  = differential pressure (Pa)

$\rho$  = air density (kg/m<sup>3</sup>)

$Q_v = \text{airflow (m}^3/\text{h)}$

$$Q_v = K \sqrt{\frac{2}{\rho} \cdot (\Delta p)}$$

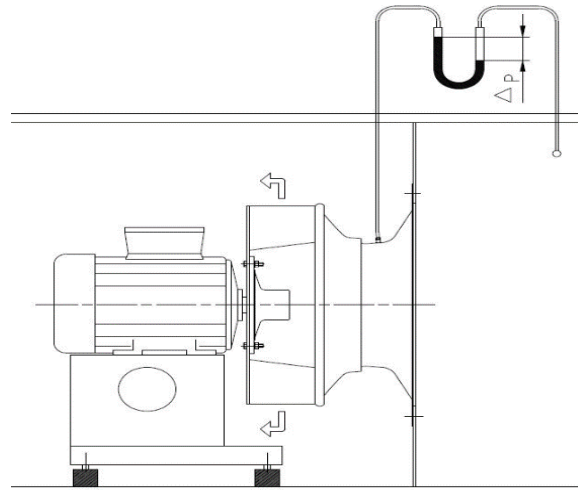

### 3.8 Assembly of a flat pack delivered AX'M unit

If the AIR ACCESS unit is delivered as a flat pack, the components are marked and plastic wrapped on a pallet.

A documentation file is with the assembly accessories. It includes an overall drawing, a manufacture drawing with marked parts and part list, and a set of sketch showing the assembly procedure and the seal settings.

The good setting at the right locations of the seals is of the greater part of the good assembly of the unit. Respect the principle sketch here enclosed.

Please see following pages the assembly procedures.

#### *Position of seals*

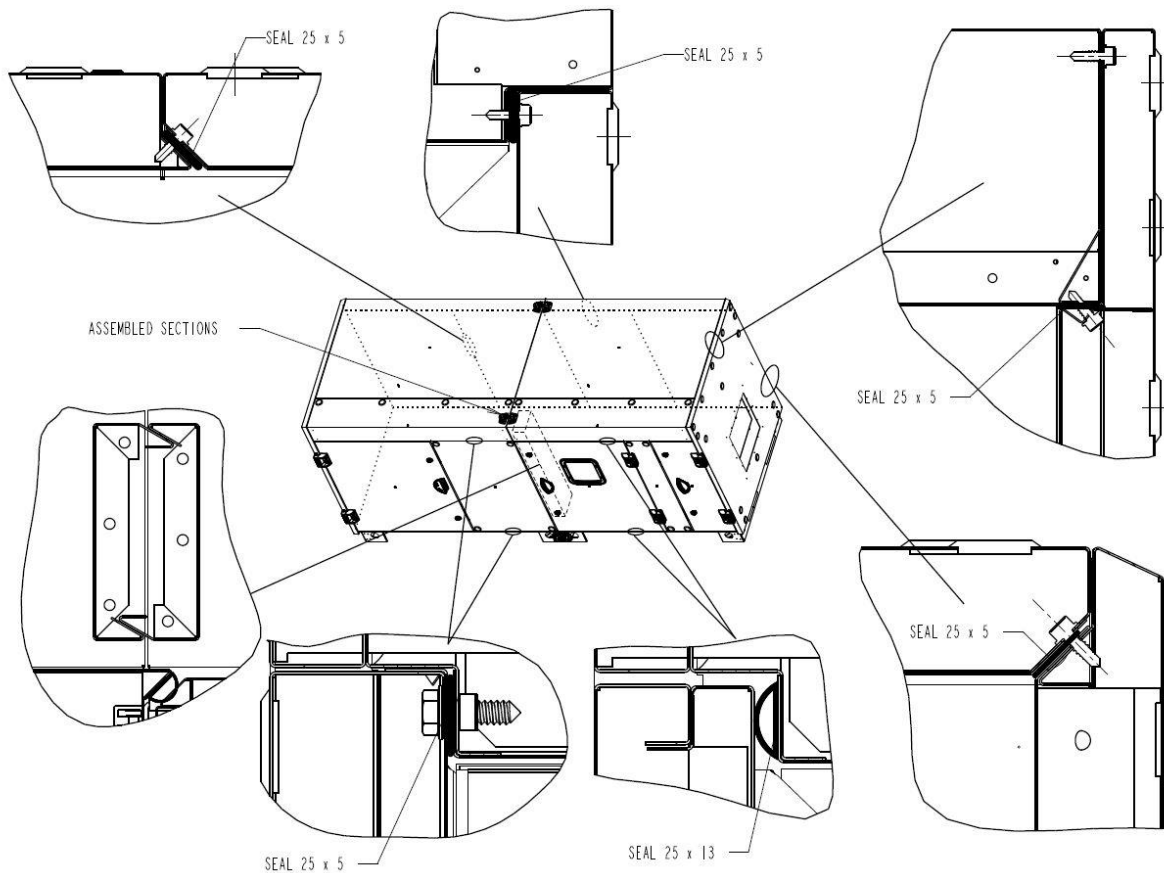

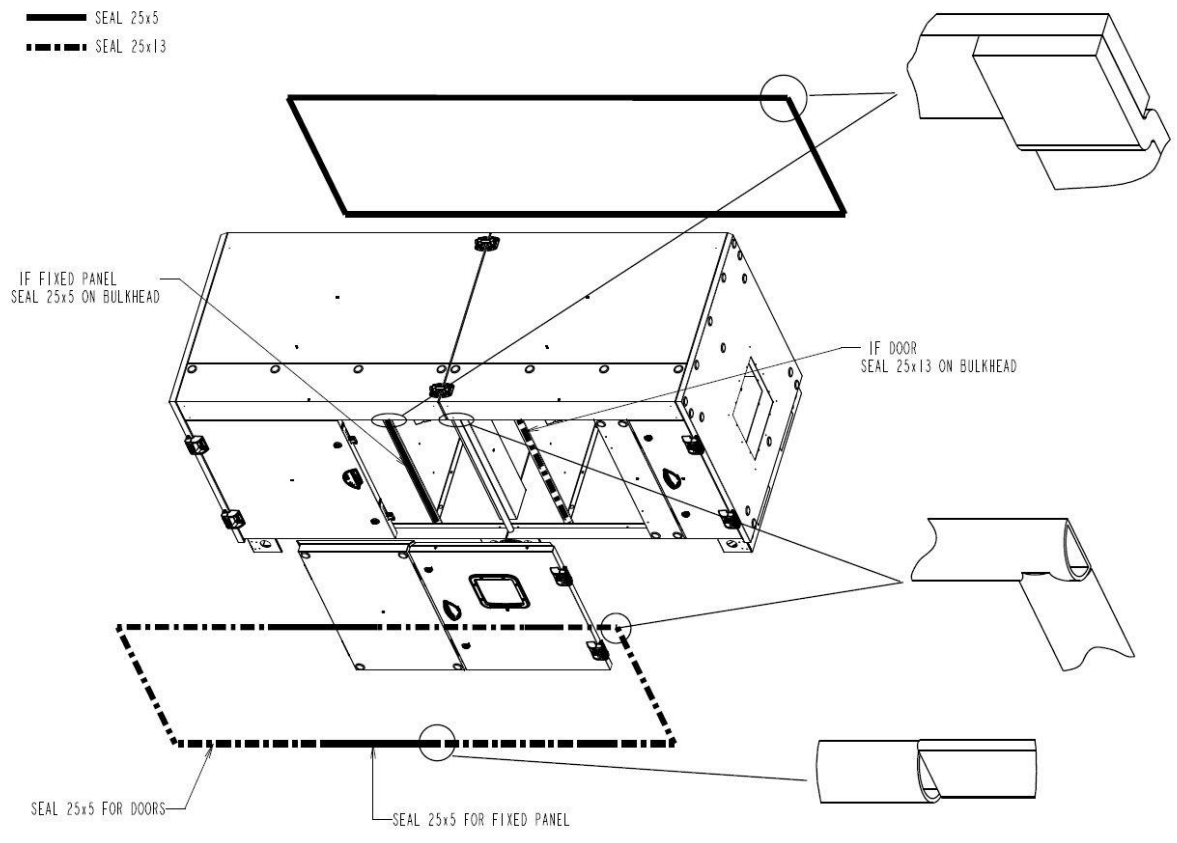

Plug fan

①

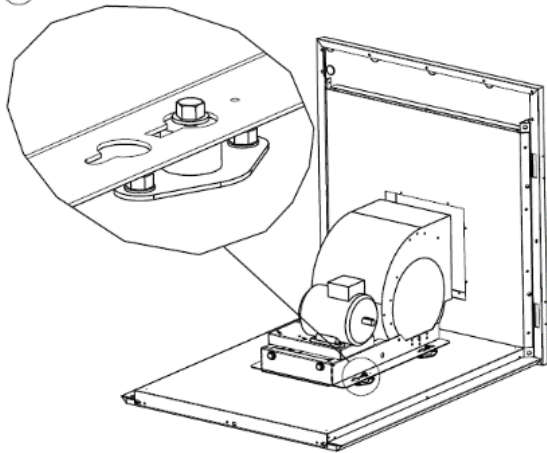

②

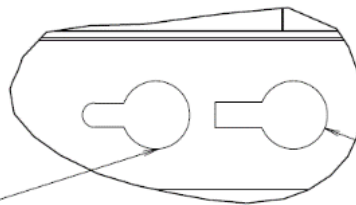
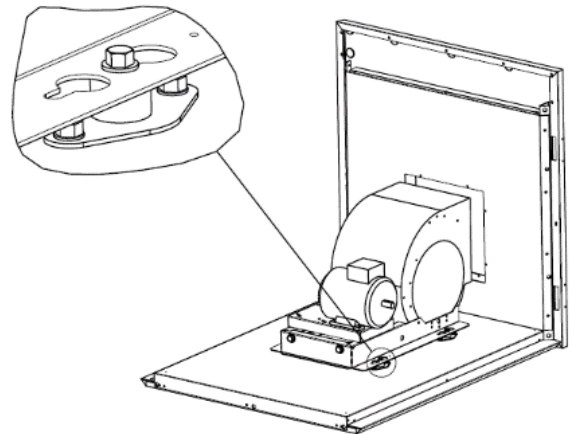

POSITION WITH FLEXIBLE SLEEVE

POSITION WITH TUBULAR SEAL

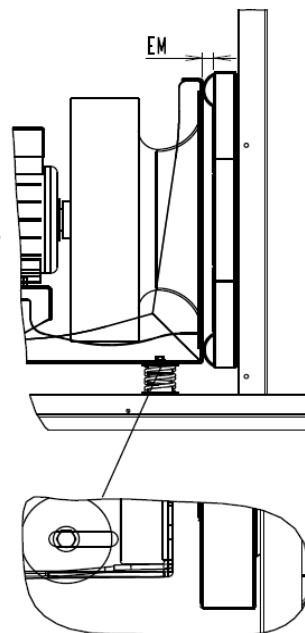
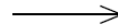
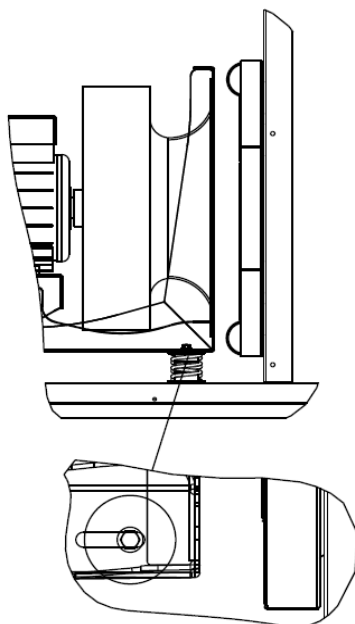
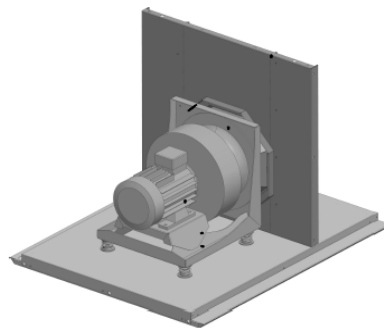

20 ≙ EM ≙ 40



## Assembly order

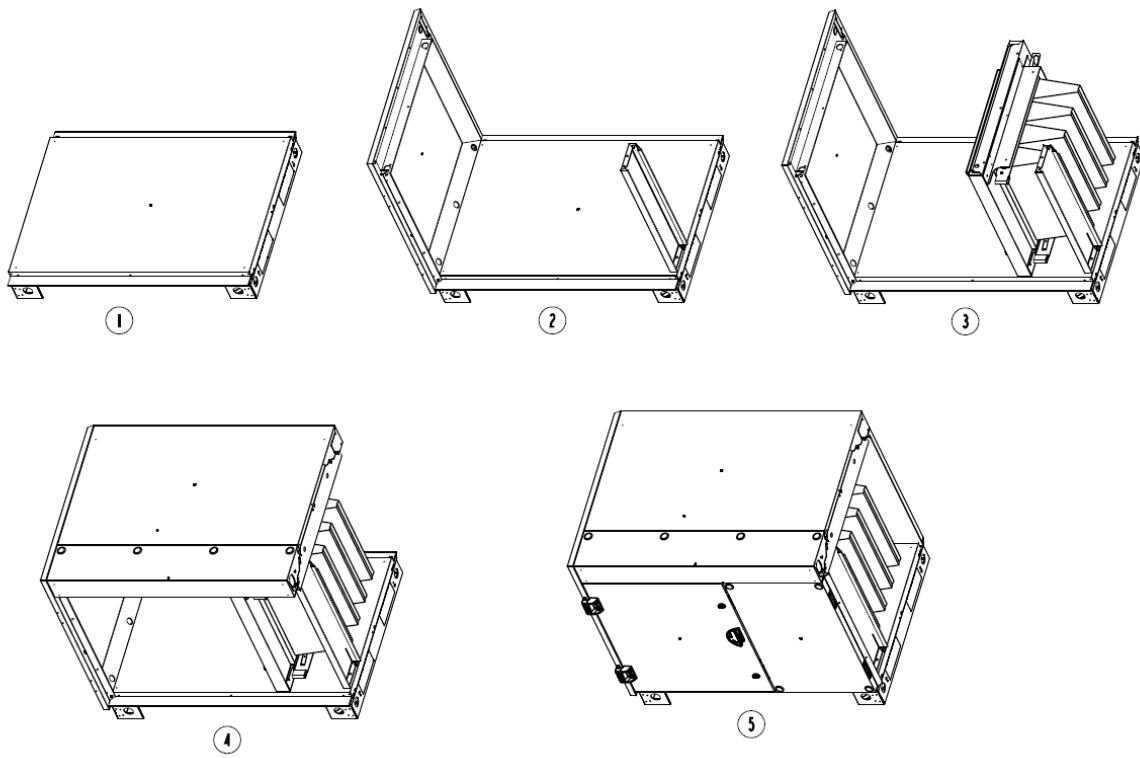

## Screws

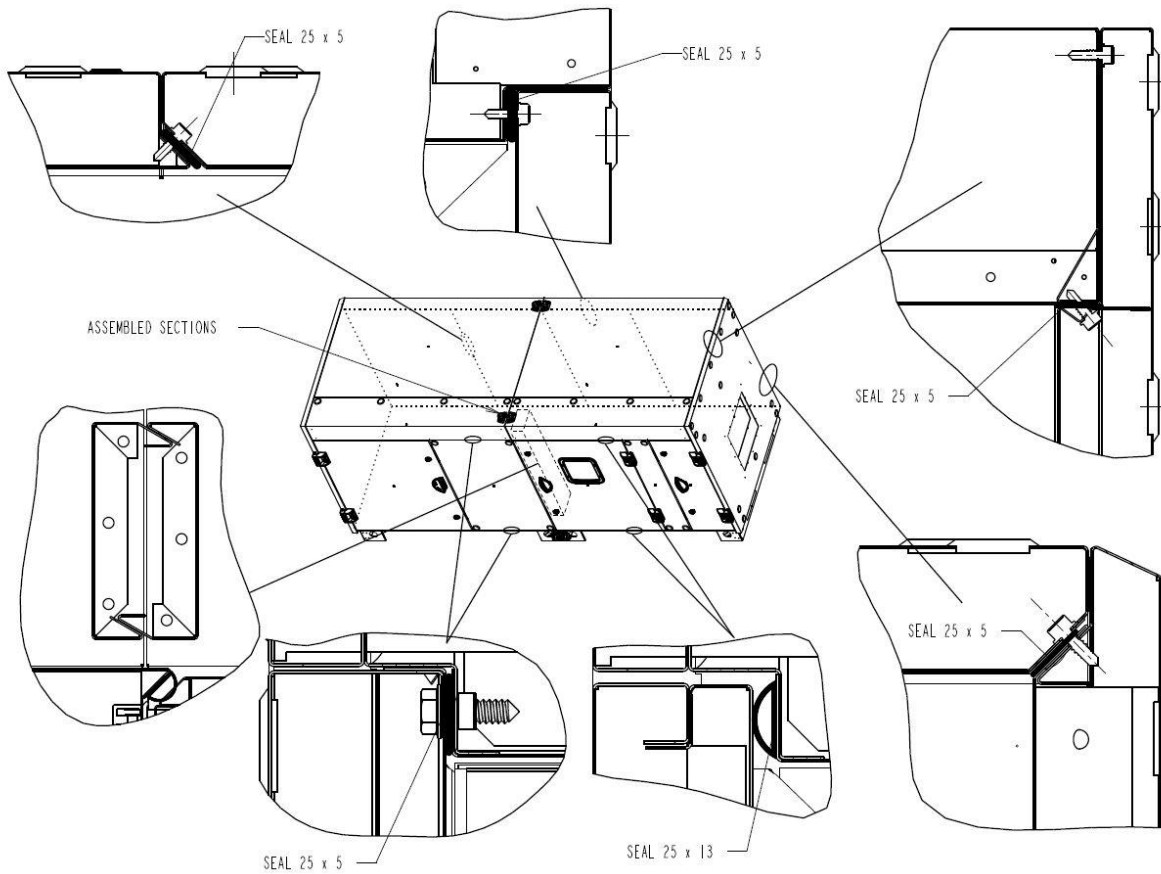



Sous reserves de modifications des produits sans préavis.